



**Techni**  
ENGINEERING SOLUTIONS

**VW TRANSPORTER 2.0L TDI EURO 6**

**T26/T27/T28/T30/T32**

---

**CODE / CODICE: 0500.8002**

**COMPRESSOR / COMPRESSEUR / KOMPRESSOR  
/ COMPRESSORE / COMPRESOR :**

**SELTEC TM15**

**QUE QP15**

---

**FITTING INSTRUCTIONS**

**EINBAUANLEITUNGEN**

**INSTRUCTIONS POUR LE MONTAGE**

**ISTRUZIONI DI MONTAGGIO**

**INSTRUCCIONES DE MONTAJE**

---



**Contents**

<b>ENGLISH</b> .....	4
Parts View.....	4
Parts List .....	5
Compressor Configurations .....	6
Standard Fastener Torque Values .....	6
Kit Details .....	7
Vehicle Details .....	7
Forward .....	7
Pre Installation.....	8
Installation .....	8
Drive belt.....	9
Finish.....	10

PARTS VIEW / VUE ÉCLATÉE / TEILEANSICHT / VISTA PARTA / IMÁGENES DE LAS PIEZAS

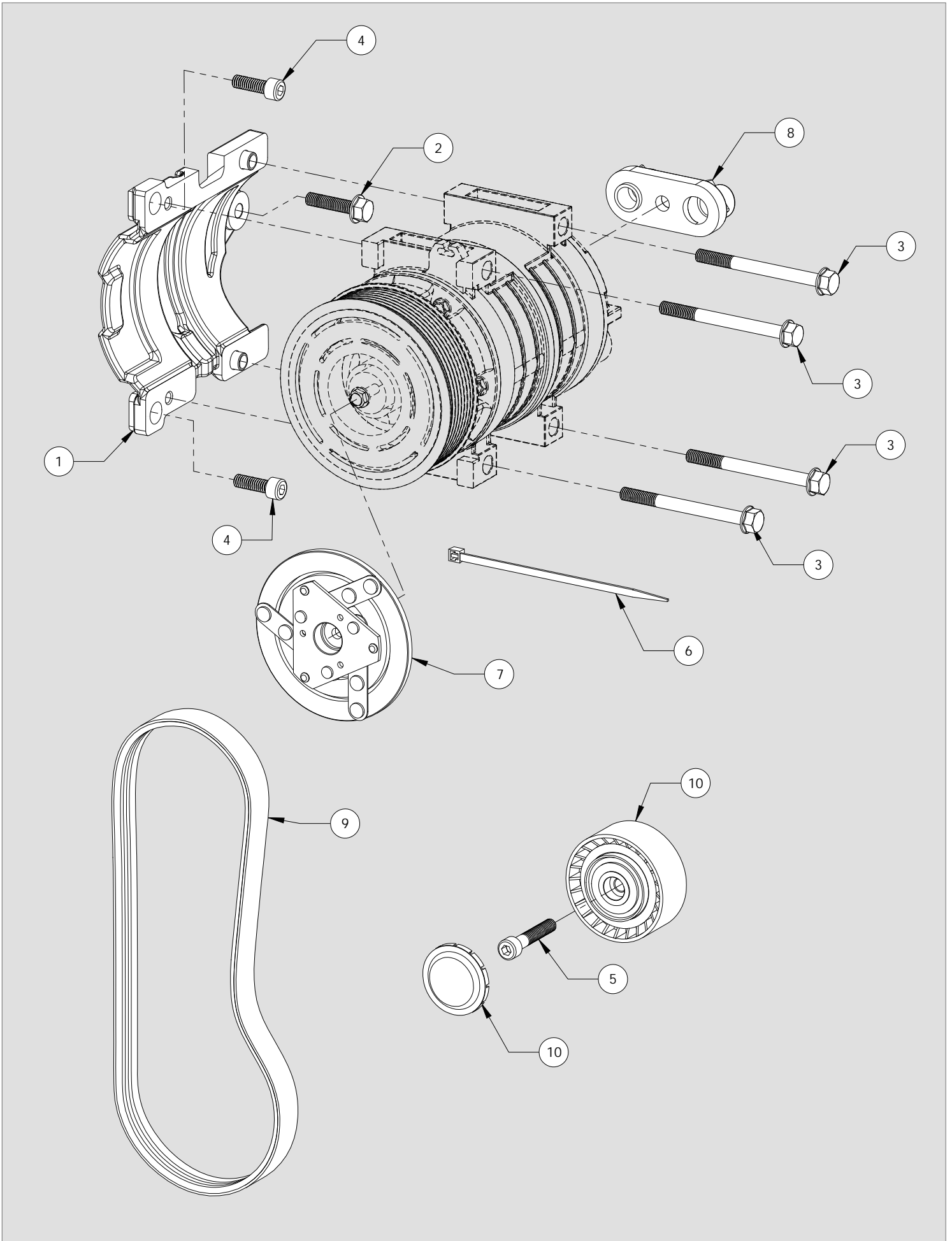

## PARTS LIST / NOMENCLATURE / TEILELISTE / ELENCO DELLE PARTI / LISTA DE PIEZAS

ITEM	CODE / CODICE / KODE / CODIGO	DESCRIPTION / DESCRIZIONE / BESCHREIBUNG / DESCRIPCION	QTY.	COMMENTS
1	0441.5035	CMB Assy - VW Transporter 2.0 2015MY No A/C - TM15 Direct	1	
2	2704.0481	Hex flange bolt Durlok - M8 x 35 : 1.25 - 12.9	1	
3	2704.5381	Hex flange bolt - M8 x 90 : 1.25 - 8.8	4	
4	2704.5371	Hex socket head cap screw M8 x 25 : 1.25 - 12.9	2	
5	2704.5341	Hex socket head cap screw M8 x 45 : 1.25 - 12.9	1	
6	2763.0051	Cable Tie 4.8 x 370 - Black	1	
7	0421.0011	Clutch Armature SL - Seltec/QUE 13/15/16	1	
8	0425.0141	Manifold Seltec/QUE H 3/4 x 7/8	1	
9	0820.7611	Belt - Poly Groove 6PK 1595	1	
10	1700.5131	Idle Pulley VW 6PK x 70	1	

**COMPATIBLE COMPRESSORS / COMPRESSEURS RECOMMANDÉS / EMPFOHLENE KOMPRESSOREN  
RACCOMANDATO COMPRESSORI / RECOMENDADAS COMPRESORES**

SELTEC	-	TM-15 HS	-
Comp No	-	0381.5072	-
Valeo No.	-	-	-
Mounting	-	Direct	-
Rotor	-	8PV	-
GL	-	-	-
Armature	-	SL	-
Diameter	-	123	-
Voltage	-	12	-
Orientation	-	H	-
Fitting	-	3/4 x 7/8	-
Manifold	-	Bolt	-

QUE	-	QP-15 HS	-
Comp No	-	0391.5102	-
Que No.	-	-	-
Mounting	-	Direct	-
Rotor	-	8PV	-
GL	-	-	-
Armature	-	SL	-
Diameter	-	123	-
Voltage	-	12	-
Orientation	-	H	-
Fitting	-	3/4 x 7/8	-
Manifold	-	Bolt	-

SANDEN	-	-	-
Comp No	-	-	-
Sanden No.	-	-	-
Mounting	-	-	-
Rotor	-	-	-
GL	-	-	-
Armature	-	-	-
Diameter	-	-	-
Voltage	-	-	-
Orientation	-	-	-
Fitting	-	-	-

NOTES

**STANDARD FASTENER TORQUE VALUES**

In the absence of specific torque values detailed in this fitting instruction manual, the following chart can be used as a guide to the maximum safe torque for specific size and grade of fastener.

**COUPLES DE SERRAGE DES FIXATIONS STANDARDS**

Si des chiffres de serrage au couple particuliers ne sont pas indiqués dans cette notice de montage, se référer au tableau suivant qui servira de guide pour le couple de sécurité maximum correspondant à une taille et un grade spécifiques de fixation.

**ANZIEHMOMENTE FÜR STANDARDBEFESTIGUNGSMITTEL**





Falls in dieser Einbauanleitung keine speziellen Anziehmomente angegeben sind, kann die folgende Tabelle als Richtlinie für das maximale sichere Anziehmoment für eine spezifische Größe oder Qualität von Befestigungsmitteln dienen.

**VALORI STANDARD DI SERRAGGIO PER DISPOSITIVI DI FISSAGGIO**

In assenza di valori specifici di coppia nel presente manuale di istruzioni, si può utilizzare la seguente tabella come guida per conoscere la coppia massima sicura in base a dimensioni e grado del dispositivo di fissaggio.

**VALORES ESTÁNDAR DE LOS PARES DE APRIETE Y FIJACIÓN**

En ausencia de valores para los pares de apriete específicos detallados en este manual de instrucciones de montaje, se puede utilizar la siguiente tabla como guía para consultar el máximo par de torsión seguro para un tamaño concreto y su grado de fijación.

STRENGTH								
	Max Torque		Max Torque		Max Torque		Max Torque	
Dia / Pitch	lb.ft	Nm	lb.ft	Nm	lb.ft	Nm	lb.ft	Nm
M5 x 0.80	2	3	4.5	6	6.5	9	7.5	10
M6 x 1.00	4	5.5	7.5	10	11	15	13	18
M8 x 1.25	10	13	18	25	26	35	33	45
M10 x 1.25	20	27	39	53	57	78	66	90
M10 x 1.50	18	25	37	50	55	73	63	86
M12 x 1.75	33	45	63	85	97	130	111	150
M14 x 2.00	55	75	103	140	151	205	177	240
M16 x 2.00	85	115	159	215	232	315	273	370

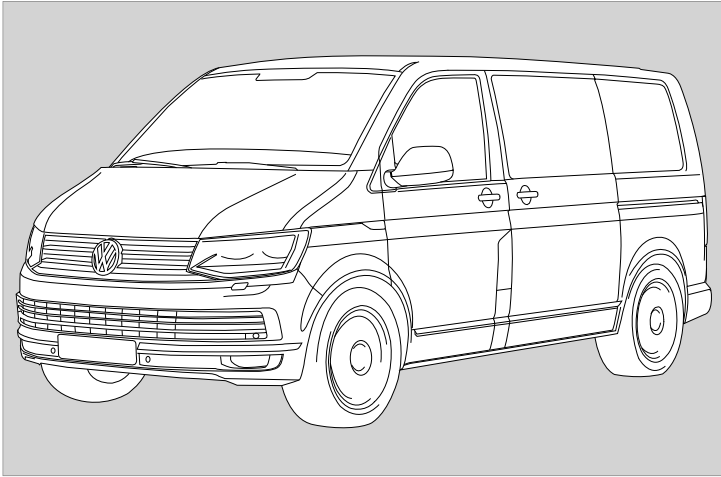

## VEHICLE DETAILS

Manufacturer	Volkswagen
Make	Transporter T6
Model Type	T26/T27/T28/T30/T32
Engine cc	2.0l TDI Euro 6
Engine Details	CXEB 150kW / CXFA 110kW / CXGA 62kW / CXGB 75kW / CXHA 110kW
Year	10/15>
Chassis Nos.	N/A
LHD	YES
RHD	YES
PAS	YES
A/C	NO
Voltage	12v

## KIT DETAILS

Kit Part Number	0500.8002
Description	Standard
Compressor RPM	4528 @ Max engine power output
Fitting Time	45 Minutes
Suction Fitting	Straight
Discharge Fitting	Straight
Belt Type	6PK 1595
Belt Part Number	0820.7611



**NOTE:** Volkswagen recommend the following Optional Equipment: **Upated Alternator & battery (NY1): Battery for electrical loads (8FB): Electrical Interface for special vehicles (IS2): Engine under panel – 7E0-805-685-A. Under panel screws N-019-530-6.** In vehicles without air conditioning, it is necessary to recode the engine control unit when an ancillary is retrofitted.

On BlueMotion Technology vehicles you should also note that the load compartment cooling system must be integrated into the BMT function so that shut-down of the engine is prevented during the cooling process (cooling system on and load compartment temperature not reached). For ease of implementation of this requirement, we recommend also ordering the multifunction control unit (IS6). Ecooling systems are excluded from BlueMotion vehicles.

## FOREWORD

The purpose of this manual is to facilitate the installation of a direct drive compressor. The information given is merely instructive, should any complications arise contact the Technical department. The manufacturer's warranty does not cover any problems caused by defective installation or alterations made unless authorised. The manufacturer shall not be responsible for any injury, damage or loss caused directly or indirectly as a result of using this manual or the information contained within it.

### 1 SAFETY MEASURES:

**Before fitting the Compressor adapter drive kit, ensure the following for damage:**

- a Inner and outer trim and body work
- b Engine idle pace
- c Check all the vehicle functions

**Check list:**

- a Ensure that the right kit has been selected
- b Before installing, check that all the correct pieces are present; also ensure that there are no missing or broken pieces
- c When fitting, make sure the vehicle is properly protected against damage.

### Installation apparatus

- a Calibrated torque wrench
- b Hand service tools
- c Protective covers and shields

### 2 PRECAUTIONS

- a Detach the battery negative lead.
- b Torque all bolts where stated using a calibrated torque wrench.
- c Take extreme care with moving parts.
- d Remove the vehicle's ignition key and keep it with you.
- e Wear safeguards and make sure that liquid refrigerant never touches your skin

**Caution:** Measures must be followed accurately to steer clear of the possibility of damage to individuals

**Warning:** This calls awareness to actions which must be pursued to avoid damage to the components.

**NB:** This calls awareness to make the job easier or gives useful information.

**REMOVAL OF PARTS**

1. Remove engine under-panel (where applicable).
2. Release automatic tensioner (A) and lock using a suitable 4mm pin. - Fig 1
3. Remove and discard drive belt (B). Fig 1.

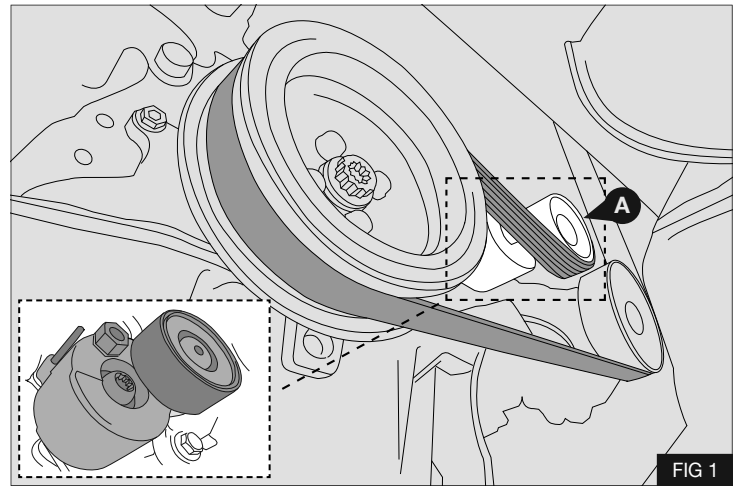

4. Remove and discard harness support block (C). - Fig 2
5. Cut cable tie (D) and remove and retain harness support (E). - Fig 2

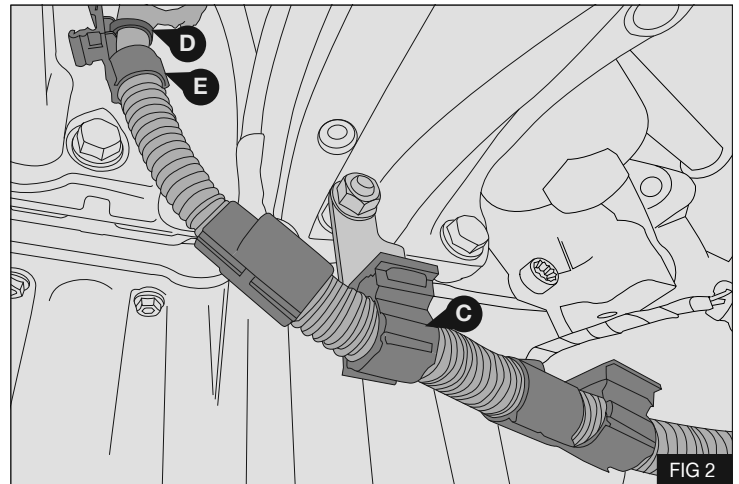
**INSTALLATION**

1. Fit compressor mounting bracket (1) using 2 x M8 x 25 hex head cap screws (4) and 1 x M8 x 35 Flange bolt (2) - Figs 3 & 4

Torque bolts (4) and (2) to 29Nm / 21.4Lbft

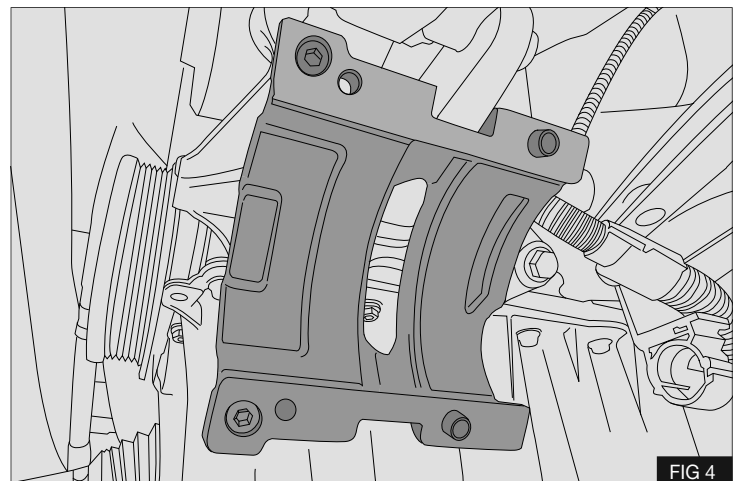
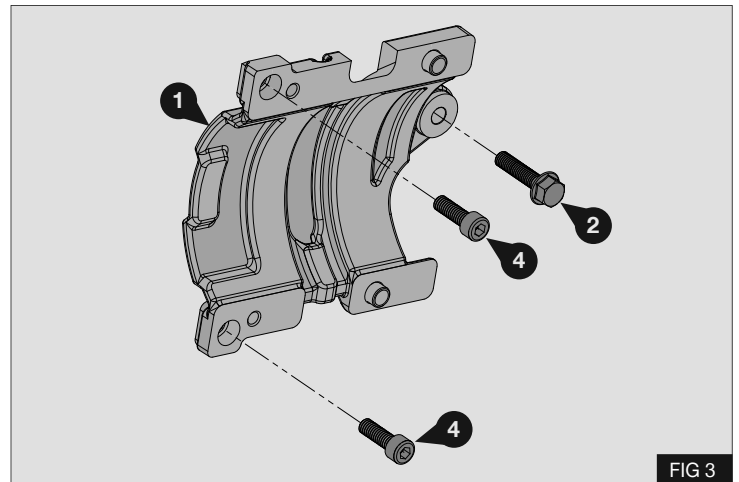



2. Install Idle pulley (10) onto existing point on the engine (F) using 1 x M8 x 45 Cap head screw (5). - Fig 5.

Torque bolt (5) to 29Nm / 21.4Lbft

3. Fit plastic cap cover

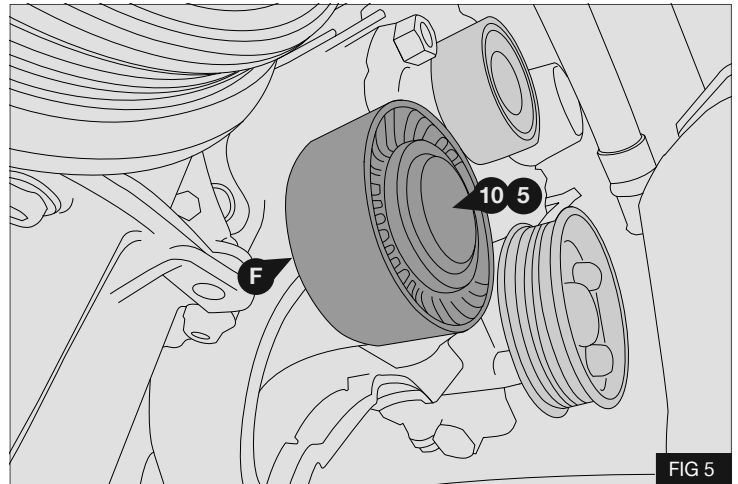

4. Fit compressor to bracket using (1) 4 x M8 x 90 flange bolts (3) - Fig 6

Torque bolts (3) to 22Nm / 16.2Lbft

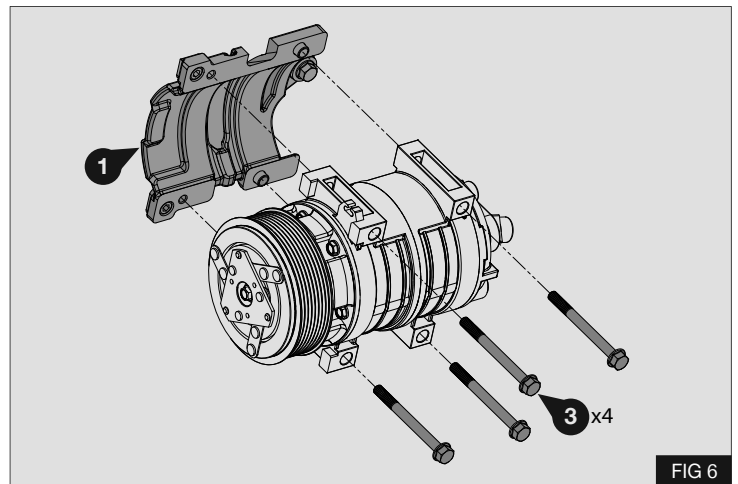

#### DRIVE BELT

1. Fit drive belt (9) as shown - Fig 7.

- A Compressor
- B Crank pulley
- C Automatic tensioner
- D Alternator
- E Power steering pump
- F Idle pulley

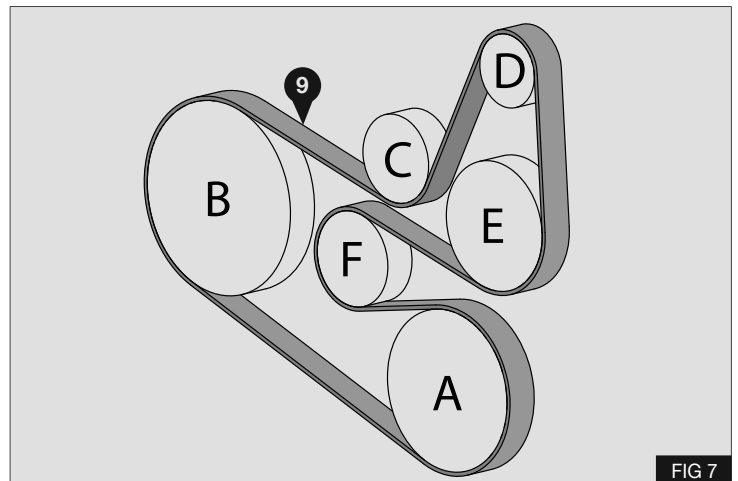

2. Position belt in compressor grooves indicated - Fig 8.

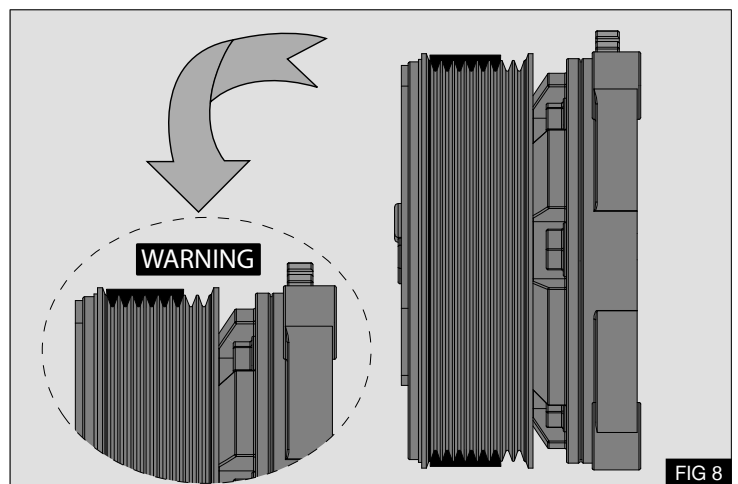

**FINISH**

1. Connect refrigerant hoses
2. Secure original harness support (E) to the location shown in Fig 9. Position harness for maximum clearance and secure to support (E) using cable tie (6) - Fig 9

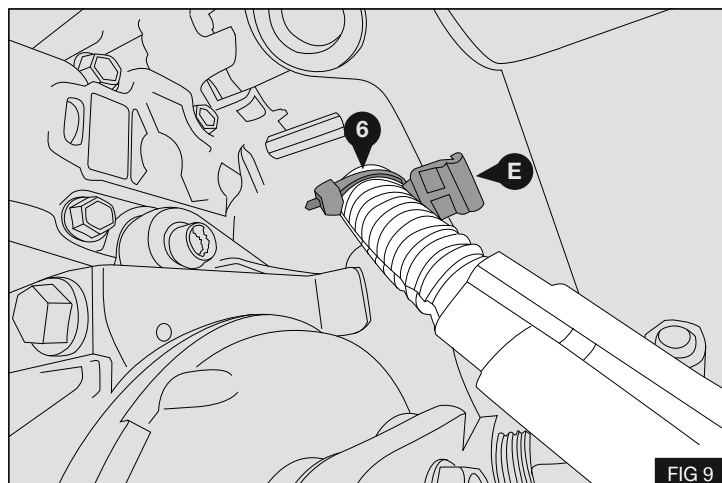

FIG 9

**UNDER PANEL**

**Note:** VW recommend the installation of the engine under panel on converted vehicles:

OEM Under panel part number – **7E0 805 685 A**  
 OEM Under panel fasteners number – **N 019 530 6**

1. Fit the engine under panel using original bolts

Torque the bolts to 12Nm / 9Lbft

**ELECTRICAL INTERFACE FOR SPECIAL VEHICLES**

(EXERPT FROM THE VW BODYBUILDERS GUIDE)

1. In principle, there are two interfaces for external use in special vehicles and by body builders:
  - a Terminal strip: 3 plugs with selected vehicle electrical system potentials
  - b **Multifunction control unit: control unit with access to the vehicle's CAN network**
2. The interfaces can be ordered using the following equipment numbers (PR numbers): SEE TABLE OPPOSITE

**Note:** The multifunction control unit (MFG) with part number 7E0.907.427.B has a CANopen interface acc. to the CIA447 specification.

PR number	Description
IS1	Terminal strip "Electrical interface for external use" (terminal strip in driver's underseat box)
IS6	Multifunction control unit "Multifunction control unit for external use" (front passenger's underseat box)
IS2	Terminal strip (IS1) and multifunction control unit (IS6) "Electrical interface and multifunction control unit for external use"

" " Sales designation

3. The multifunction control unit **IS6** is installed in the seat box of the front passenger seat. For vehicles with individual seats the multifunction control unit is installed to the right on the seat box and for vehicles with double seats to the front on the seat box.
4. The terminal strip **IS1** is installed in the seat box of the driver's seat and is located by the coupling point.

## ELECTRICAL INTERFACE FOR SPECIAL VEHICLES

1. Multifunction control unit (IS6)
2. Terminal strip (IS1)

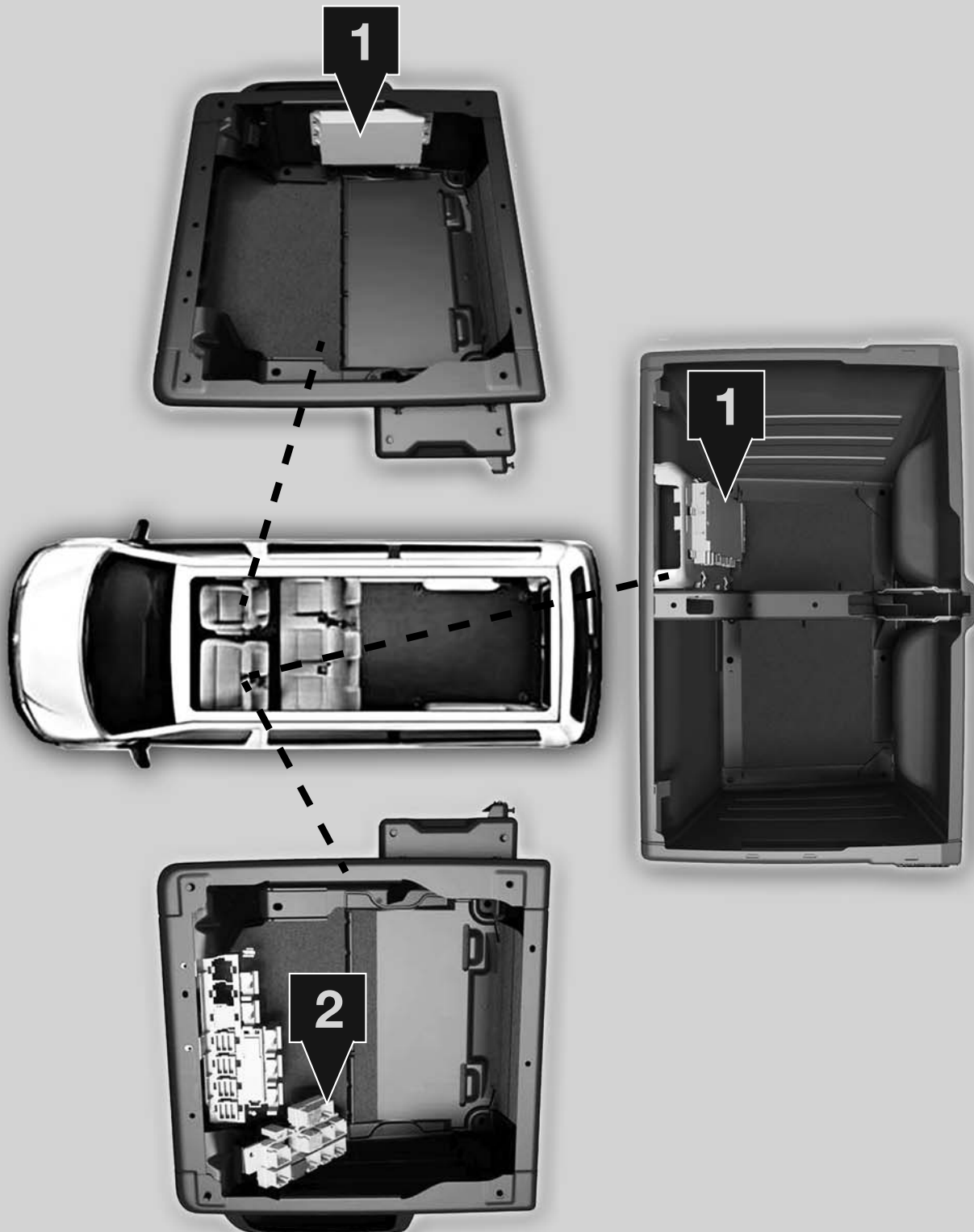

## CONTACT ASSIGNMENT ON THE MULTIFUNCTION CONTROL UNIT (IS6)

- Discrete signals with terminal 30 level can be picked off at all highside outputs of the multifunction control unit. Signals with terminal 31 level can be picked off at all lowside outputs. The outputs can be loaded up to the particular prescribed value. The inputs of the control unit must be connected to earth (low active) or to positive (high active), according to specification.
- The following plugs and contacts must be used for connecting external devices to the special vehicle control unit:

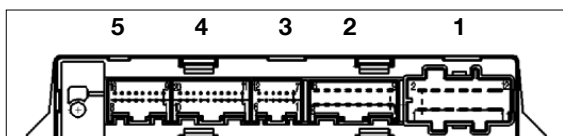

	Plug 5	Plug 4	Plug 3	Plug 2	Plug 1
<b>Part Number</b>	8E0.972.416.A	8E0.972.420	Not assigned	443.972.807	4B0.973.721
<b>Contacts</b>	Pin 3 – 16: 0.5 mm <sup>2</sup> N.907.649.01	Pin 1 – 20: 0.5 mm <sup>2</sup> N.907.649.01		Pin 1 – 16: 0.5 – 1 mm <sup>2</sup> N.101.905.01 1.5 – 2.5 mm <sup>2</sup> N.101.906.01	Pin 1 – 8: 0.5 – 1 mm <sup>2</sup> N.906.844.01 1.5 – 2.5 mm <sup>2</sup> N.906.845.01

## PLUG 4 ASSIGNMENT

Pin	Designation	Type	Function
1	E01	Input/active low	Activation of ignition bypass safety circuit
2	E02	Input/active low.	n.c.
3	E03	Input/active low	Activation of the buzzer (gong) in the instrument cluster; The frequency and duration of the activation can be set in the parameters
4	E04	Input/active low	Activation of front left electric window for opening the side window
5	E05	Input/active low	Activation of front left electric window for closing the side window
6	E06	Input/active low	Deactivation of the daytime running light (only with BCM max) <sup>2</sup>
7	E07	Input/active low	Activation of front right electric window for opening the side window
8	E08	Input/active low	Activation of front right electric window for closing the side window
9	E09	Input/active low	Activation of the hazard warning lights; The function only responds to the button. Press once = switch on, second press = switch off
10	E10	Input/active low	Activation of the central locking; Momentary contact input for closing (safe) the central locking
11	E11	Input/active low	Activation of the central locking; Momentary contact input for opening the central locking
12	E12	Input/active low	n.c
13	E13	Input/active low	n.c
14	E14	Input/active low	Activation of the vehicle horn
15	E15	Input/active low	Activation for the intermittent light/flasher unit. By setting the parameters of the control unit, it is possible to define which bulbs should be activated <sup>2</sup>
16	E16	Input/active low	<b>Deactivation of the engine start/stop system in the vehicle; Deactivation is continuous for as long as the input is activated (even after terminal change)</b>
17	E17	Input/active low	Activation of the interior lighting/suppression of the interior lighting <sup>1</sup>
18	E18	Input/active low	n.c.
19	Reserve		
20	Reserve		

<sup>1</sup> The function depends on the parameter settings of the control unit.

<sup>2</sup> Statutory regulations must be complied with.







(EN)

Techni focuses on constant upgrading of its products. The Manufacturer reserves the right to modify the models and components described in the present publication at any time for technical or commercial reasons and without prior notice. For further information, contact Techni technical services.

(DE)

Techni ist stets bestrebt die eigenen Produkte zu verbessern. Die Herstellerfirma behält sich das Recht vor, aus technischen oder Verkaufsgründen, zu jeder Zeit und ohne vorherige Ankündigung, Abänderungen an den Modellen und den in dieser Veröffentlichung beschriebenen Einbauteile vorzunehmen. Für weitere Informationen bitten wir Sie, sich an unseren Techni Kundendienst zu wenden.

(FR)

Techni vise à une amélioration constante des ces produits. La maison se réserve le droit d'apporter, à tout moment et sans préavis, des modifications aux modèles et aux composants décrits dans cette publication pour des raisons d'ordre technique ou commerciale. Pour d'ultérieures informations s'adresser au service d'assistance Techni.

(IT)

Techni mira ad un costante miglioramento dei propri prodotti. La Casa si riserva il diritto di apportare in qualunque momento e senza preavviso modifiche ai modelli e ai componenti descritti in questa pubblicazione per ragioni di natura tecnica o commerciale. Per ulteriori informazioni rivolgersi al servizio assistenza Techni.

(ES)

Techni aspira a un constante mejoramiento de su producción. La Fábrica se reserva el derecho de aportar en cualquier momento y sin preaviso modificaciones a los modelos y los componentes descritos en esta publicación por razones técnicas o comerciales. Para ulteriores informaciones dirigirse al servicio asistencia Techni.

VENDITA E SERVIZIO  
VENTE ET SERVICE

SALES AND SERVICE  
VERKAUF UND SERVICE



Sundorne Trade Park, Henley Way,  
Shrewsbury, United Kingdom, SY1 4NS  
Telephone (+44) (0) 1743 443176  
Fax (+44) (0) 1743 443113  
Email: [sales@techni.co.uk](mailto:sales@techni.co.uk)